

MAIN TECHNICAL FEATURES M60 ST/CB

SWEEPING WIDTH

• with central roll-brush only	1300 mm
• with central roll-brush and right-hand side brush	2000 mm
• with central roll-brush and 2 side brushes (standard)	2700 mm
• with central brush, 2 side brushes and 3rd front brush (opt)	3600 mm

HOPPER AND WATER TANK

Hopper volume	6 m ³
Net homologated payload	6000 Kg
Hopper dumping height	1,1m (opt=2,30m)
Water tank capacity (with optional water spraying system)	620 l / (opt 1220 l)

ENGINE AND DRIVE SYSTEM

Mercedes diesel engine Tier3 Intercooler - water cooled	110 kW/147 Hp
Driving system	hydrostatic
Maximum speed	42 Km/h
Maximum gradient full load	>20 %

OTHER FEATURES

Turning radius	4430 mm
Steering system	4-wheel power st.
Full load weight (without/with 3rd front extendable brush)	13250/13400 Kg

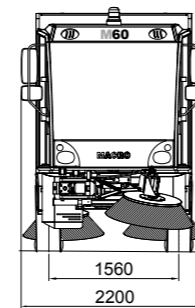
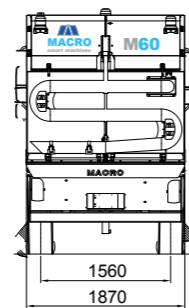
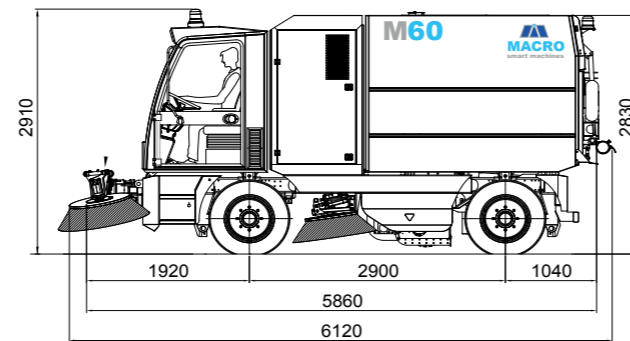

M60 ST/CB are also available with **EURO 5** (soon **EURO 6**) EMISSION STANDARDS installing Mercedes diesel engine Intercooler Euro5 AdBlue® water-cooled - 130 kW / 177 HP.

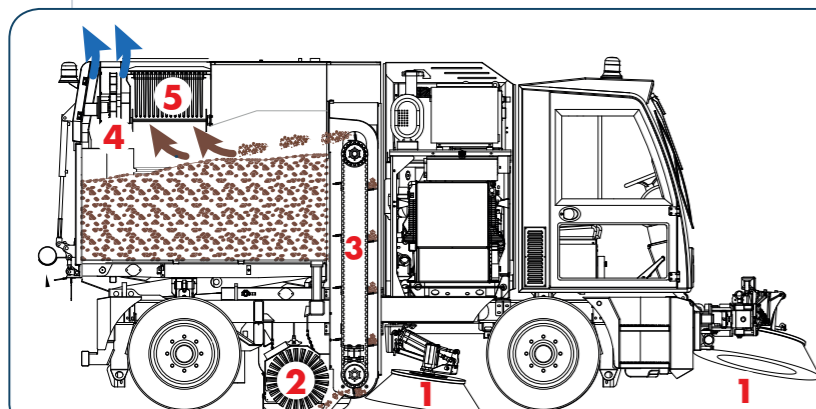

MECHANICAL-SUCTION SYSTEM

The waste is collected by the mechanical action of the side (1) and central (2) brushes and the vertical loading conveyor (3). The suction (4) is only aimed at capturing the dust as soon as it's raised up from the floor. The suction is optimized to allow the full suppression of dusts thanks to large surface filter (5).



Established in 1991 Macro has over 20 years experience in heavy-duty and precision steel fabrication and in the manufacturing of cleaning equipment for major international brands. Inheriting Macro advanced technology along with RCM large world-wide organization, Macroclean aims at becoming soon the leading manufacturer of heavy-duty industrial and street sweepers.

MACROCLEAN S.r.l. ph. +39 0523 248636 www.macroclean.it info@macroclean.it
Operational Headquarter: Via Bonati 38, 29017 Fiorenzuola D'Arda (PC) - Registered Head Office: Via Tiraboschi 4, Casalalbo (Mo) - Italy

[an RCM company]

M60

THE TRUE **R**EVOLUTION IN HEAVY-DUTY SWEEPING

SCAN
to watch the video



EN



06/2015 REV.2

M60



M60

The **M60** is the most advanced and performing mechanical-suction sweeper on the market today thanks to years of continuous development. Its **6 cubic meter hopper volume** and **6000 Kg net payload** are unmatched performances that allow this superb sweeper to work in the heaviest-duty conditions, both urban and industrial. **The very large surface filters make the machine work dust-free** even in the dustiest situations. To the well-known and appreciated characteristics and reliability of the ST version, the CanBus (CB) version adds further unparalleled and innovative performances.



CANBUS

Controller Area Network Bus

IT IS AN ADVANCED SYSTEM THAT CONNECTS ALL THE MODULES WORKING THROUGHOUT THE MACHINE SO THAT THEY CAN WORK TOGETHER TO RUN EFFECTIVELY AND EFFICIENTLY. IT IS HIGHLY RELIABLE AS COMING FROM THE AUTOMOTIVE SECTOR:

- USER-FRIENDLY KEYPAD - "EASYSTART" ONE-BUTTON FOR ALL REQUIRED FUNCTIONS ON/OFF
- FRONT/REAR HYDRO-PNEUMATIC "REACTIVE" SUSPENSIONS MACRO LAC® PATENT
- BRUSHES GROUND PRESSURE PNEUMATIC CONTROL, FOR WEAR REDUCTION
- AUTOMATIC CENTRAL AND SIDE BRUSHES RAISE AND WATER SHUT-OFF IN REVERSE
- POSSIBILITY OF AUTOMATIC VACUUM ADJUSTMENT DEPENDING ON THE TYPE OF WORK
- "LOAD SENSING" HYDRAULIC SYSTEM FOR REDUCING FUEL CONSUMPTION AND SERVICE COSTS
- HIGH-PRECISION WEIGHING DEVICE OF LOADED MATERIAL, AND LOAD LIMITING DEVICE
- IN-CAB MONITOR WITH PARTIAL/TOTAL HOUR-COUNTER OF ALL MACHINE FUNCTIONS
- DIAGNOSTICS DIRECTLY DISPLAYED ON MONITOR
- REMOTE UPDATE OF ANY POSSIBLE SETTING VIA SIMPLE USB STICK OR NETWORK CABLE
- USER AND PARTS MANUALS SUPPLIED CAN ALSO BE CONSULTED ON MONITOR
- ACQUISITION, DISPLAY AND RECORDING OF ANY OPERATION DATA

MAIN OPTIONALS



Fully adjustable third front brush that allows to sweep 180° left and right side.



Dumping at any height between 1,1 and 2,3 m.



Rear powerful wandering vacuum hose, 6 m length -140 mm diameter.



Side brush dust suppression skirts for dry dust-free sweeping.



Very large volumes of dry collected waste. 6 m³ hopper and 6000 kg payload is the highest capacity on the market, allowing long working shifts.



Sweeping and climbing over 20% full-load. The 4-wheel steering gives the M60 excellent manoevrability in all working conditions.



Exclusive capability to sweep in unbalanced conditions (ex. sidewalks). The system allows to sweep on bumps with no operator's action required.



Spacious and comfortable cabin with 3 homologated seats and user-friendly controls.



Easy-to-use keypads to operate the machine. "EasyStart" single button for all required functions on/off (CB).



Large retention dust filter to work dust-free in any situation, with filtration level available up to PM2,5.