

M40

THE TRUE **R**EVOLUTION IN HEAVY-DUTY SWEEPING



EN

MACRO
smart machines

M40



MAIN OPTIONALS



The M40 is the most advanced and performing mechanical-suction sweeper on the market today thanks to years of continuous development. Its **4 cubic meter hopper volume** and **2600 Kg net payload** are unmatched performances that allow this superb sweeper to work in the heaviest-duty conditions, both urban and industrial. **The very large surface filters make the machine work dust-free** even in the dustiest situations. The well-known and appreciated characteristics and reliability of the CanBus system adds further unparalleled and innovative performances.

CANBUS

Controller Area Network Bus

IT IS AN ADVANCED SYSTEM THAT CONNECTS ALL THE MODULES WORKING THROUGHOUT THE MACHINE SO THAT THEY CAN WORK TOGETHER TO RUN EFFECTIVELY AND EFFICIENTLY. IT IS HIGHLY RELIABLE AS COMING FROM THE AUTOMOTIVE SECTOR:

- USER-FRIENDLY KEYPAD - "EASYSTART" ONE-BUTTON FOR ALL REQUIRED FUNCTIONS ON/OFF
- AUTOMATIC CENTRAL AND SIDE BRUSHES RAISE AND WATER SHUT-OFF IN REVERSE
- IN-CAB MONITOR WITH PARTIAL/TOTAL HOUR-COUNTER
- DIAGNOSTICS DIRECTLY DISPLAYED ON MONITOR



Very large volumes of dry collected waste. 4 m3 hopper and 2600 kg payload is the highest capacity on the market, allowing long working shifts



The machine is available also in 4 wheels traction configuration, for the most demanding environments.



Exclusive capability to sweep in unbalanced conditions (ex. sidewalks). The system allows to sweep on bumps with no operator's action required.

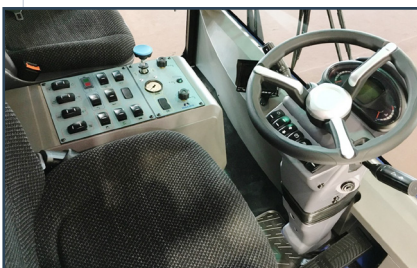

Spacious and comfortable cabin with 2 homologated seats and user-friendly controls.



Easy-to-use keypads to operate the machine. "EasyStart" single button for all required functions on/off.



Large retention dust filter to work dust-free in any situation, with filtration level available up to PM 1 (optional).

MAIN TECHNICAL FEATURES M40

SWEEPING WIDTH

• with central roll-brush only	1300 mm
• with central roll-brush and right-hand side brush	1900 mm
• with central roll-brush and 2 side brushes (standard)	2500 mm
• with central brush, 2 side brushes and 3rd front brush (opt)	3300 mm

HOPPER AND WATER TANK

Hopper volume	4 m ³
Hopper dumping height	1,05 m (opt÷2,10 m)
Water tank capacity (with optional water spraying system)	400 l

ENGINE AND DRIVE SYSTEM

VM diesel engine stage 3	80 kW/107 Hp
VM diesel engine Euro 6	80 kW/107 Hp
Driving system	hydrostatic
Maximum speed	42 Km/h

OTHER FEATURES

All functions control	Electro-hydraulic
Steering system	4-wheel power st.

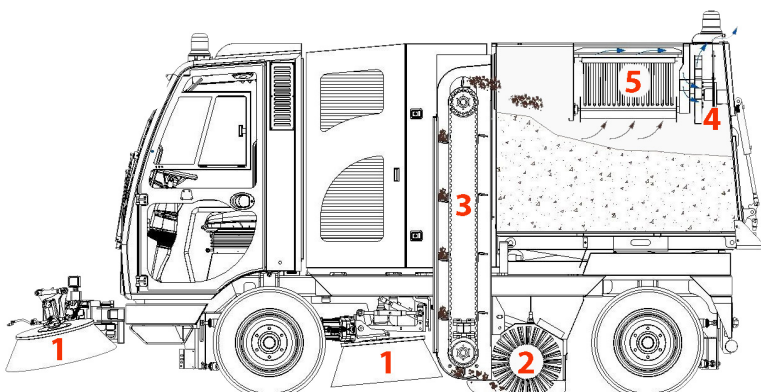
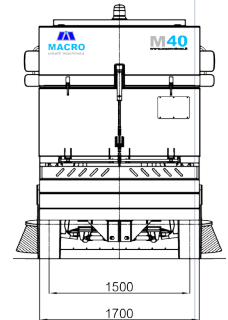
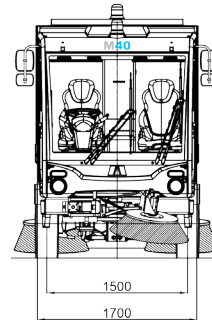
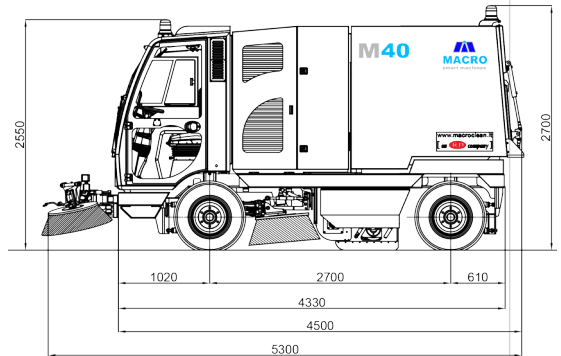

MECHANICAL-SUCTION SYSTEM

The waste is collected by the mechanical action of the side (1) and central (2) brushes and the vertical loading conveyor (3). The suction (4) is only aimed at capturing the dust as soon as it's raised up from the floor. The suction is optimized to allow the full suppression of dusts thanks to large surface filter (5).

OPTIONS AVAILABLE

- 180° right/left-hand front pivoting brush assembly (3300 mm total sweeping width)
- right/left-hand side brush casing kit for dry dust-control on side brushes
- water spraying system for r/l-hand side brushes with 400 L stainless steel water tank
- High pressure washing system (140÷200bar) w. spray-gun and 12m-hose reel
- Hopper hydraulic high dump mm 1005÷2100
- Heavy-duty rear vacuum wand complete w.flexible hose (6m total length/140mm Ø)
- Ultra-high performance Tetratex dust-filter PM1 (99,5%)
- Magnetic bar
- Vertical conveyor's larger surface palettes for very dusty/sandy working conditions
- Extra performace tracion for hig slopes
- Centralized manual greasing system (grease pump not included)
- Personalized colour

MACRO•CLEAN

Established in 1991 Macro enjoys a long experience in steel fabrication, as well as in the manufacturing of cleaning equipment for major international brands and of large sweepers. Inheriting and developing Macro advanced technology

along with RCM large organization, Macroclean has rapidly become a leader in the production and sales of road and industrial sweepers and today offers the widest range of mechanical-suction sweepers from 0,3 to 6 m³.

MACROCLEAN S.r.l. ph. +39 0523 248636 www.macroclean.it info@macroclean.it
Operational Headquarter: Via Bonati 13, 29017 Fiorenzuola D'Arda (PC) - Registered Head Office: Via Tiraboschi 4, Casalalbo (Mo) - Italy